	DimLight	Document no: n/a	Revision: 1.6	Page: Page 1 of 13
	Object: Datasheet DimLight	Author: SL	Date: 2010-12-07	

DimLight

Simply dimmable

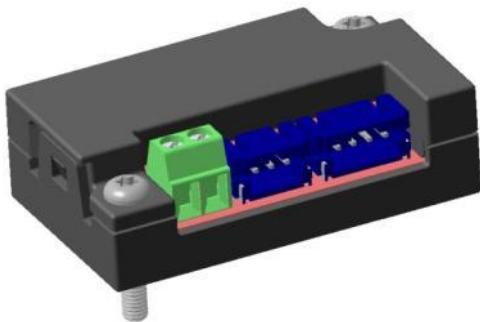
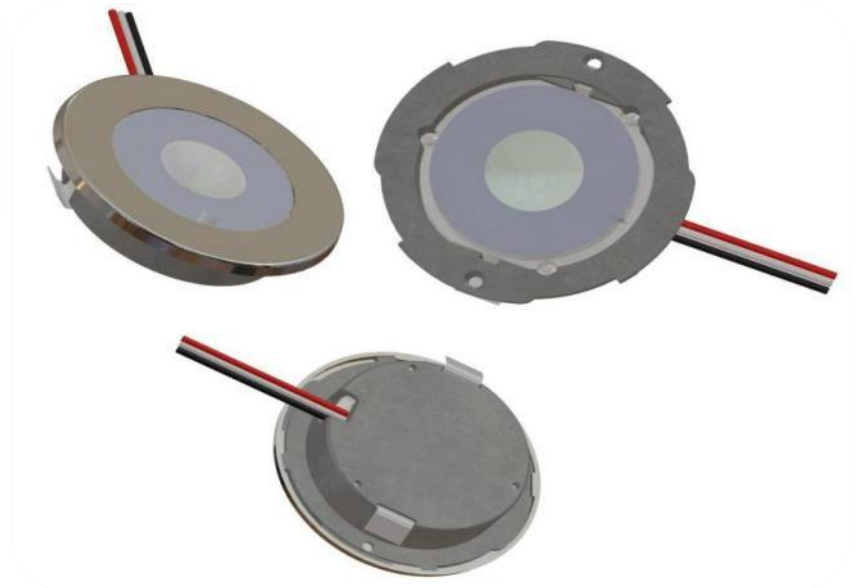
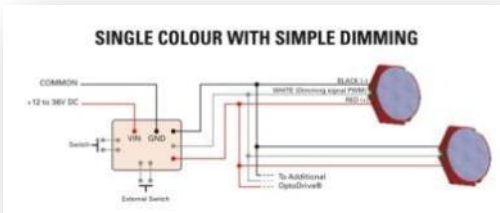

This LED dimmer module is designed for simple dimming for all Optodrive versions with integrated driver (ID). It is very simple to use when an integrated on/off and dimming is required.

- *Just connect power and connect the Optodrive module to light it up*
- *Low voltage 12-36VDC*
- *Simple fitting – no caps, just screws and plug*
- *Operates for 50,000 hours*
- *Maximum energy efficiency*

	DimLight	Document no: n/a	Revision: 1.6	Page: Page 2 of 13
	Object: Datasheet DimLight	Author: SL	Date: 2010-12-07	

Pages for reference:

Short form Characteristics.....	3
Article number structure.....	4
Characteristics for the dimmer signal.....	5
<i>Reference information about the LED module that are dimmed.</i>	5
Wiring diagram	5
Options	6
Dimensions LED Module:.....	10
Electro Optical data	11
Lifetime (Calculated)	12
Precaution for use.....	13
ROHS Compliant	13
Design for Environment:	13

	DimLight	Document no: n/a	Revision: 1.6	Page: Page 3 of 13
	Object: Datasheet DimLight	Author: SL	Date: 2010-12-07	

Short form Characteristics

Mechanical

PCB dimensions: 25 x 44 mm diameter
Connectors Power: Screw Max 0.75 mm²
Connectors Out: JST PH

Mechanical Box

Height: 14.1 mm
Diameter: 47 x 28 mm
Assembly holes: 3.3 mm

Electrical:

Number of outputs: 1
Power supply: 12 - 36VDC
Max current out: 2A

Reversed polarity protection: Yes
Transient protection: Yes
Overvoltage protection: No
Dimming signal transient protection: Yes

Dimming Signal:

PWM high level: 4 – 7V
PWM low level: 0 – 0,5V
PWM frequency¹: 100 – 20kHz

Environmental operating conditions:

Temperature Ambient T_a: Max 50°C
Temperature range on PCB: -40°C to 65°C (Absolute maximum temp T_c 65°C)
Relative Humidity: 10-75%
Ambient air pressure: 500-1060 HPa

	DimLight	Document no: n/a	Revision: 1.6	Page: Page 4 of 13
	Object: Datasheet DimLight	Author: SL	Date: 2010-12-07	

Article number structure

Template:

Name V.C1.C2.C3

Example:

DimLight Switch Box.S.H.H

Name: Module name
DimLight Switch
DimLight Pulse
DimLight 0-10V
DimLight Dali

V: Version
PCB = PCB only
Box = PCB in box

C1: Connector 1, Power Input Connector
S = Screw connector
H = Header connector (Snap in connector)

C2: Connector 2, Power Output Connector
S = Screw connector
H = Header connector (Snap in connector)

C3: Connector 3, Dimming signal Input Connector
S = Screw connector
H = Header connector (Snap in connector)

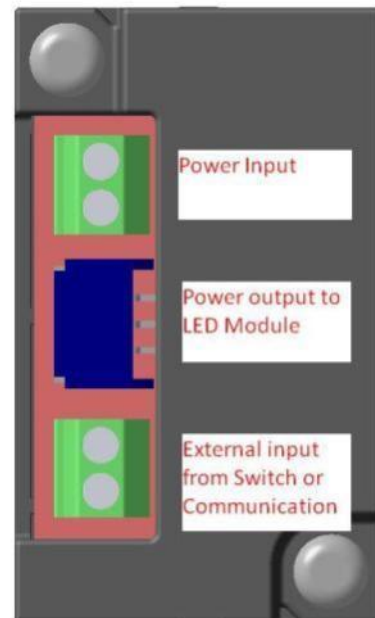

	DimLight	Document no: n/a	Revision: 1.6	Page: Page 5 of 13
	Object: Datasheet DimLight	Author: SL	Date: 2010-12-07	

Characteristics for the dimmer signal

Reference information about the LED module that are dimmed.

The OptoDrive LED Module is dimmable by means of an external dimmer signal located in the centre of the power supply connector.

The dimmer signal is preferably supplied from an opto-isolated signal source (open-collector) referred to the power ground. The rise and fall time should be kept as low as possible to reduce power dissipation. The signal source must be able to sink a current of $V_{in} / 90k \text{ A}$. Note that the power dissipation increases with higher dimming switching frequency.

The LED array is “ON” when the dimmer signal is left floating (or not connected).
The LED array is “OFF” when the dimmer signal is grounding.

Several OptoDrive can be connected in parallel without degradation in performance. However, due to the lowered impedance of the internal voltage divider, the efficiency will be slightly degraded.

Wiring diagram

SINGLE COLOUR WITH SIMPLE DIMMING

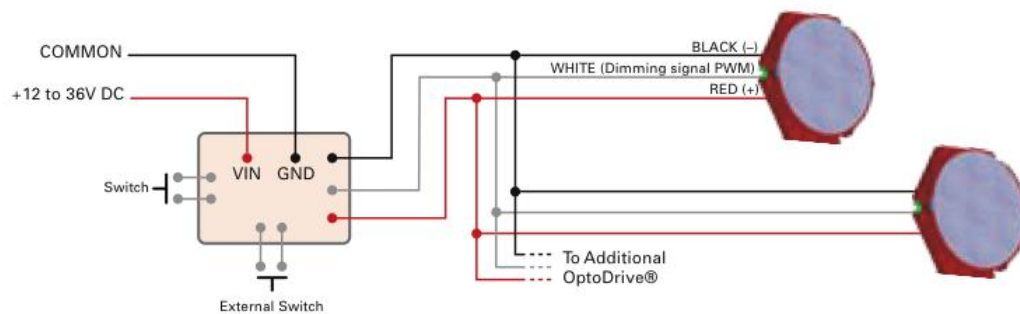

Options

DimLight Switch

Mainly used in application with external switch that is of momentary type.
 Connector 1 from the left is Power In, Connector 2 is connected to the LED Module of type ID and the connector 3 is a connection to the momentary switch.

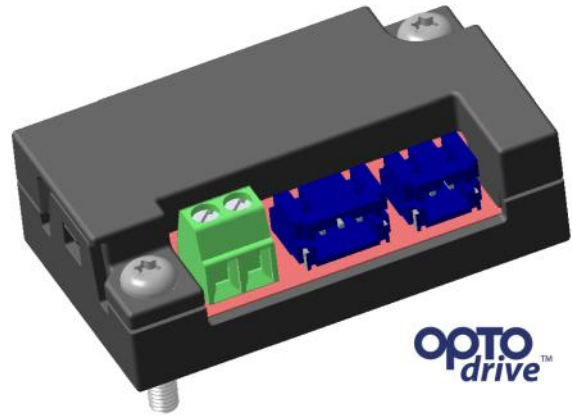

Standard Wire DimLight Switch

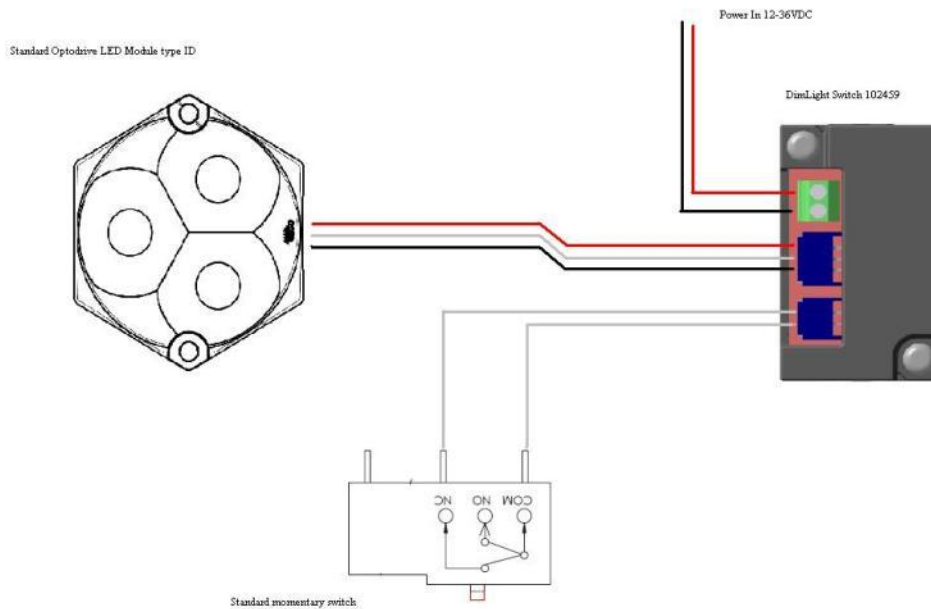

Standard Wire DimLight Switch

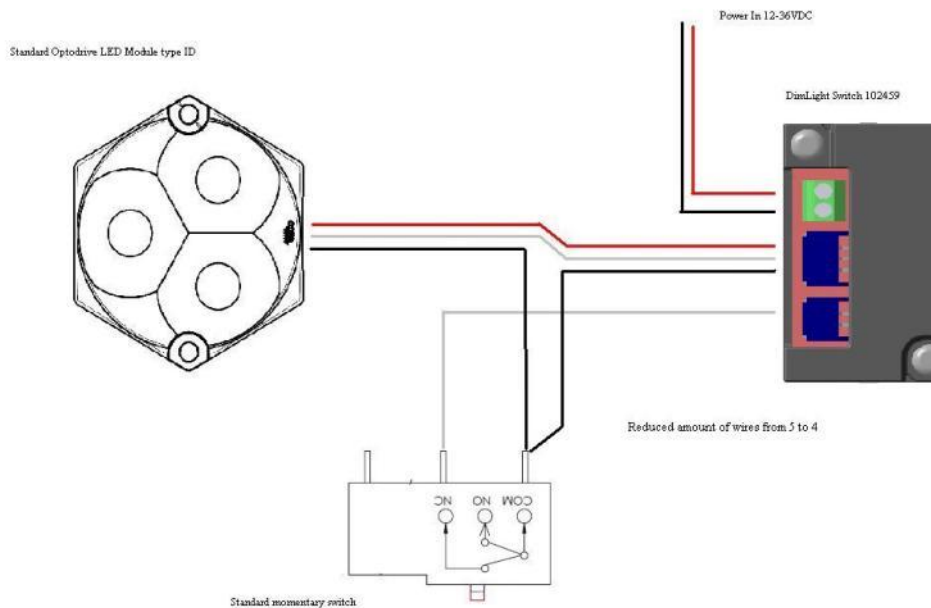

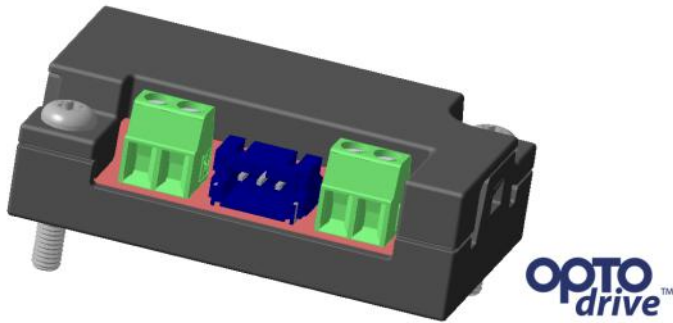

	DimLight	Document no: n/a	Revision: 1.6	Page: Page 7 of 13
	Object: Datasheet DimLight	Author: SL	Date: 2010-12-07	

DimLight DALI

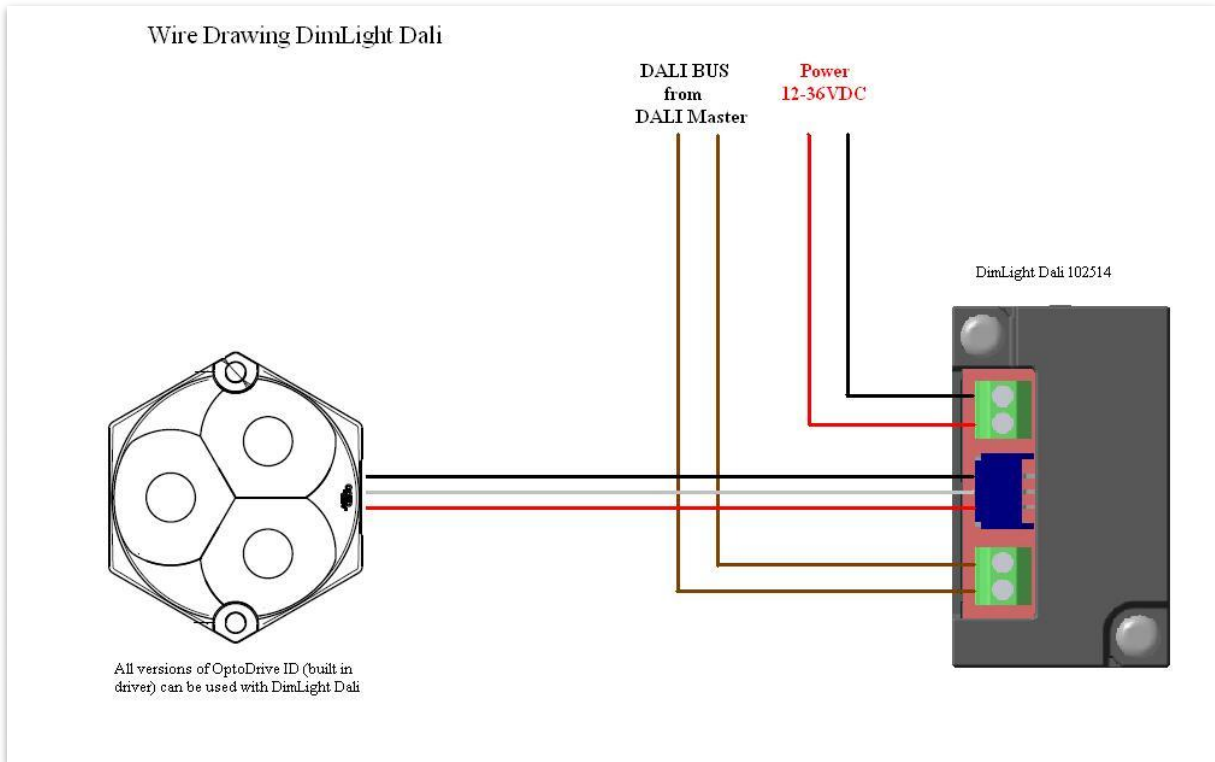

Used in application with Dali networks as a nod for a LED module of type ID. Connector 1 from the left is Power In, Connector 2 is for the LED module and Connector 3 is for the DALI bus.



	DimLight	Document no: n/a	Revision: 1.6	Page: Page 8 of 13
	Object: Datasheet DimLight	Author: SL	Date: 2010-12-07	

DimLight Pulse

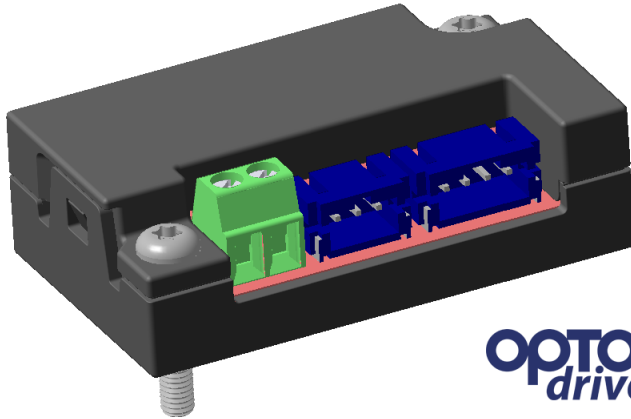

This is to be used with an encoder. By using an encoder in an application the real feedback to the end user can be made, both by the eyes and by the vibration inside the encoder that are felt during dimming.

- Connector 1 Power in
- Connector 2 I/O to Optodrive LED module type ID
- Connector 3 To the PulsSwitch

Wire Drawing DimLight Pulse

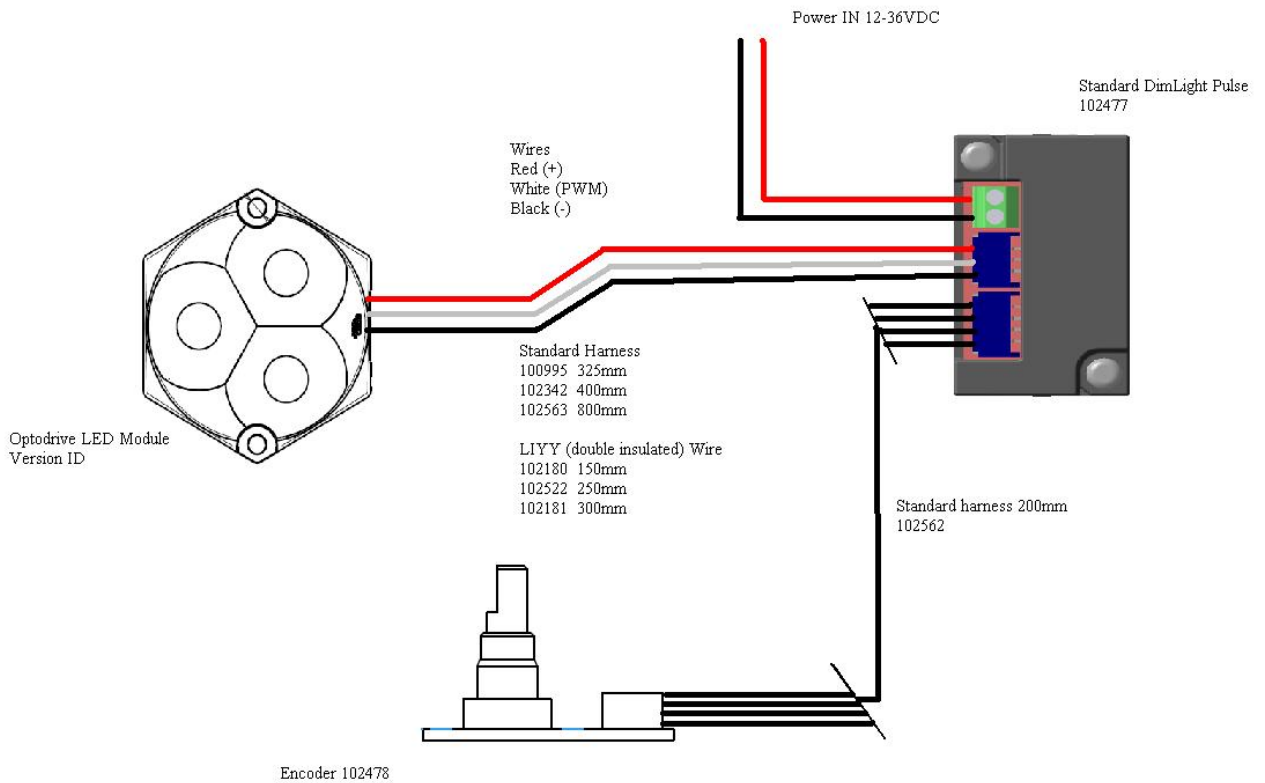

	DimLight	Document no: n/a	Revision: 1.6	Page: Page 9 of 13
	Object: Datasheet DimLight	Author: SL	Date: 2010-12-07	

DimLight 0-10V

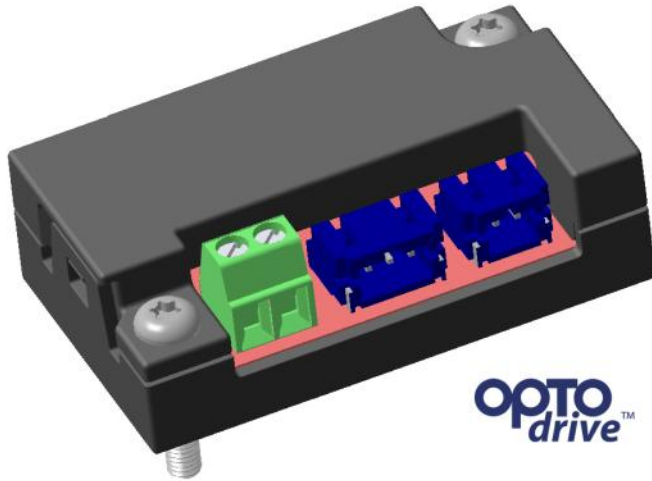



The 0-10V version of DimLight is to be used together with standard 0-10V dimmers.

- Connector 1 Power in
- Connector 2 I/O to Optodrive LED module type ID
- Connector 3 To the 0-10V dimmer

DimLight	Document no: n/a	Revision: 1.6	Page: Page 10 of 13
	Object: Datasheet DimLight	Author: SL	Date: 2010-12-07

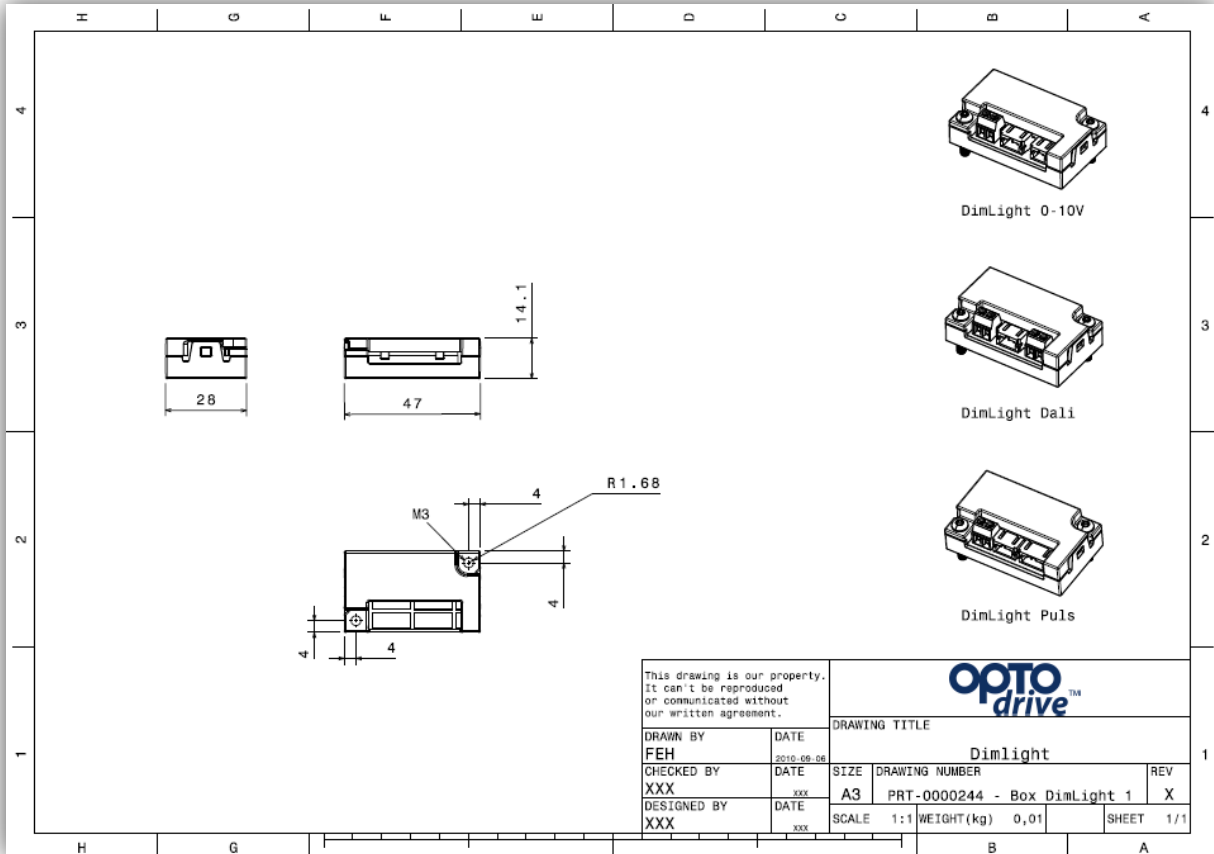
Dimensions LED Module:



	DimLight	Document no: n/a	Revision: 1.6	Page: Page 11 of 13
	Object: Datasheet DimLight	Author: SL	Date: 2010-12-07	

Electro Optical data

No change in the CCT or IEC 1931 is taking place when the Optodrive is connected and being dimmed. The colour coordinates are totally stable.

Junction Temperature Characteristics

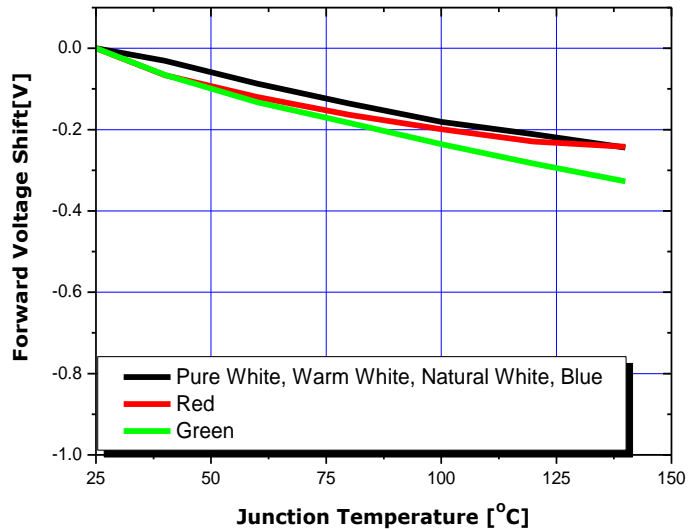

The power load is lowered to the unit Optodrive when is dimmed down so there can be a difference in light output due to cooler running of the LED module.

	DimLight	Document no: n/a	Revision: 1.6	Page: Page 12 of 13
	Object: Datasheet DimLight	Author: SL	Date: 2010-12-07	

Lifetime (Calculated)

The lifetime is calculated at the maximum temperature recommended at the Tc (measuring point). It is important not to exceed this recommendation. The use of a dimmer will extend the life time of the LED module significantly.

	DimLight	Document no: n/a	Revision: 1.6	Page: Page 13 of 13
	Object: Datasheet DimLight	Author: SL	Date: 2010-12-07	

Precaution for use

- This device should not be used in any type of fluid such as water, oil, organic solvent etc.
- When the LEDs are illuminating, operating current should be decided after considering the package maximum temperature.
- The appearance and specifications of the product may be modified for improvement without notice.
- Long time exposure of sunlight or occasional UV exposure will cause lens discoloration.

ROHS Compliant

All our modules meet the Restriction of Hazardous Substances (RoHS)!

There has been a growing consensus that Lead Free Systems should increase for the safety of our environment. It is a very serious problem that lead and other harmful materials are being used in commercial and industrial products, causing more and more environmental problems. This has led to regulations such as RoHS (Restriction of the use of certain Hazardous Substances) from the EU and the Japan Ministry of Trade and Industry (MITI). All LED makers providing products to these countries should comply with these restrictions. In order to meet RoHS regulation, Optoga is strictly implementing a ban on lead and other hazardous materials in its products. This is in compliance with our responsibilities as good corporate citizens.

Design for Environment:

According to the EU-directive 2002/95/EC (RoHS) the following substances must not be used in this product

- Lead (Pb) alloys
- Mercury (Hg)
- Cadmium (Cd)
- Chromium (6+) compounds