	Felicia ED Dome	Document no: n/a	Revision: 1.1	Page: Page 1 of 15
	Object: Datasheet Felicia EDP7 Dome Warm White	Author: SL	Date: 2010-08-17	

Felicia ED Warm White 10W Module Solution for light fitting integration

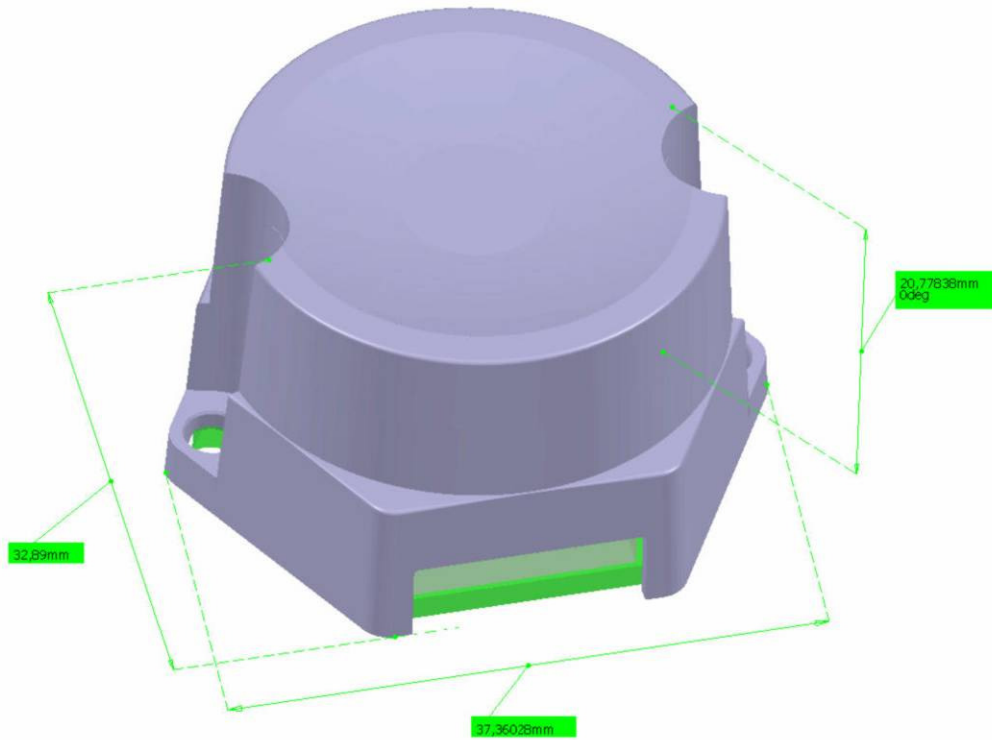

This LED Module is designed to be used with external driver and is therefore very easy to connect in applications. The efficiency are the highest available on the market for such applications.

Description

Optodrive Felicia series is designed for high current operation and high flux output applications. Optodrive LED's thermal management performance exceeds other power LED solutions. It incorporates state of the art SMD design and Thermal emission material as well as the most efficient technology. The white color Optodrive LED solution is the first built driver package designed, using high performance power chips and rendering a perfect white light.

Light Performance

The standard light temperature is 2950 and 5350 Kelvin with Colour Rendering Index with a type value better than CRI 80 on 2650 up to 3500K. The light temperatures 3700 K and above have a CRI of 70.

	Felicia ED Dome	Document no: n/a	Revision: 1.1	Page: Page 2 of 15
	Object: Datasheet Felicia EDP7 Dome Warm White	Author: SL	Date: 2010-08-17	

Pages for reference:

<i>Short form Characteristics</i>	3
Mechanical	3
Electrical.....	3
Article number structure.....	3
<i>Wiring diagram:</i>	4
<i>Dimensions LED Module:</i>	5
Parameters of the Lens system	6
<i>Parameters of the light output</i>	7
Warm White	7
Module Performance Warm White	8
Voltage vs. Current.....	8
Current vs Flux.....	8
Ambient Temperature vs Allowable Forward Current.....	9
Binning and Labelling	10
Short form letter for colour	10
Luminous Flux Bins pro LED.....	10
Forward Voltage.....	10
<i>Binning structure graphical representation</i>	11
Warm White Binning (2600 – 3700K).....	11
<i>Optics performance</i>	12
Medium Version	12
Wide Asymmetric Version of centre 10°	12
<i>Measurement Control</i>	13
<i>Lifetime</i>	14
<i>Precaution for use</i>	15

	Felicia ED Dome	Document no: n/a	Revision: 1.1	Page: Page 3 of 15
	Object: Datasheet Felicia EDP7 Dome Warm White	Author: SL	Date: 2010-08-17	

Short form Characteristics

Mechanical

Board dimensions: 34.56 mm diameter
 Assembly holes: 2 x 3.2 mm
 Wire Connector: CP04-03S0 or
 direct connect with wire without connector
 Height: 20.8 mm

Electrical

Number of LED's: 1
 Power supply: External Driver
 Power: 10 W
 LED current: Connector 1000 mA +/-10% ea.
 Wire direct connect 2800mA

Article number structure

Article number: Felicia ED10X01xxWS**zz-00

Felicia: Module name
 ED: External driver required
 10: Power (Watt)
 X: Forward Voltage Vf
 01: Amount of LED
 xx: Color
 W: Luminous Flux Bin
 S**: Binning Color
 zz: Viewing angle (NN without lens system)
 00 00 is standard and will not be notified (01 with wire locking connector)

Wiring diagram:

Se separate wiring diagram documentation.

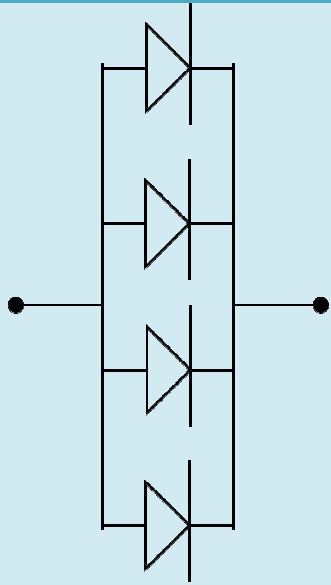
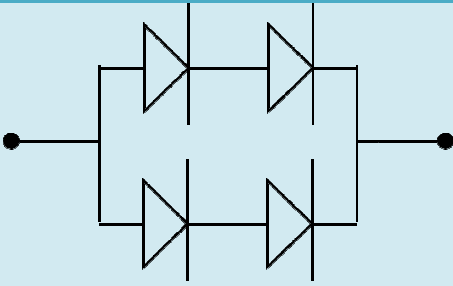
	Felicia ED with P7 Cool white	Felicia ED P7-II Warm white
Circuit diagram		
Max IF	2800mA (700mA per chip)	1400mA (700mA per chip)
Typ IF	1400mA (350mA per chip)	700mA (350mA per chip)
VF	3~4V	6~8V
CRI	70	77
Luminous Flux	Typ 750lm (@2800mA)	Typ 330lm (@700mA)

Felicia ED Dome		Document no: n/a	Revision: 1.1	Page: Page 5 of 15
Object: Datasheet Felicia EDP7 Dome Warm White		Author: SL	Date: 2010-08-17	

Dimensions LED Module:

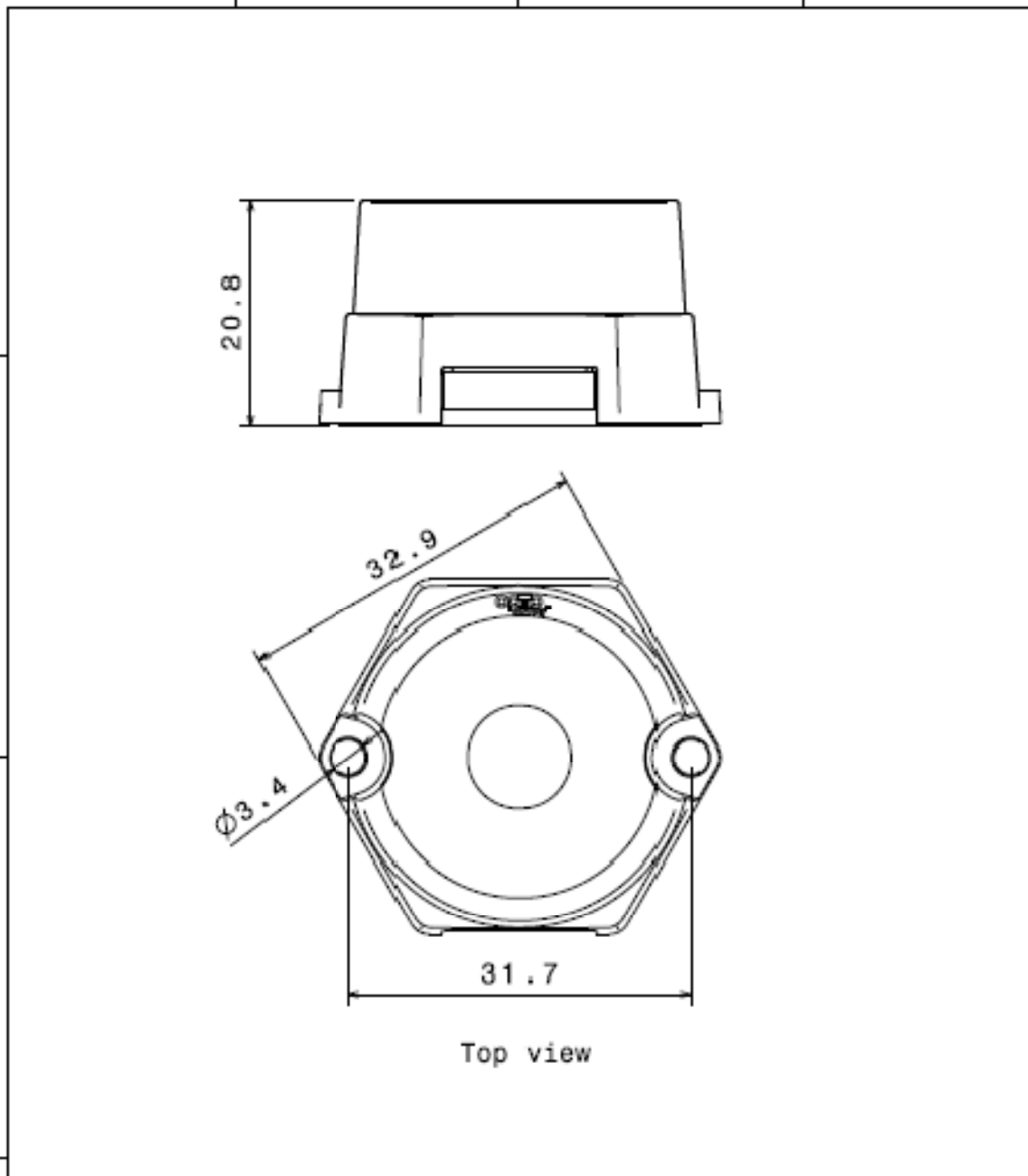

Top view

This drawing is our property. It can't be reproduced or communicated without our written agreement.				
DRAWING TITLE		Felicia1-A integ.Lens-pcb assembly		
DRAWN BY pv	DATE 27.01.2009	SIZE A4	DRAWING NUMBER	REV 1.0
CHECKED BY fk	DATE 28.07.2008	SCALE 2:1	WEIGHT(g)	SHEET 1/1
DESIGNED BY hh	DATE 23.07.2008			

Measurement given in mm

	Felicia ED Dome	Document no: n/a	Revision: 1.1	Page: Page 6 of 15
	Object: Datasheet Felicia EDP7 Dome Warm White	Author: SL	Date: 2010-08-17	

Parameters of the Lens system

The lens system is mounted and fixated on to the PCB with press fit solution to keep the parts connected to each other. They can be separated from each other without damage. The light parameters are according to the following:

Version	Viewing Angle	FWHM Angle
Felicia Smooth Spot ⁽¹⁾	14°	±7°
Felicia Diffuser ⁽¹⁾	20°	±10°
Felicia Medium	30°	±15°
Felicia Wide ⁽¹⁾	60°	±30°
Felicia Wide Asymmetric of Centre 10°	AS	-

(1) Versions are in development

Lens material optical grade PMMA.

- Allows use of high current and temperature conditions
- Best available optical efficiency, up to 90%
- Very even color distribution over the whole beam angle
- Integrated holder. Fastening to heat sink with two screws
- Compact dimensions

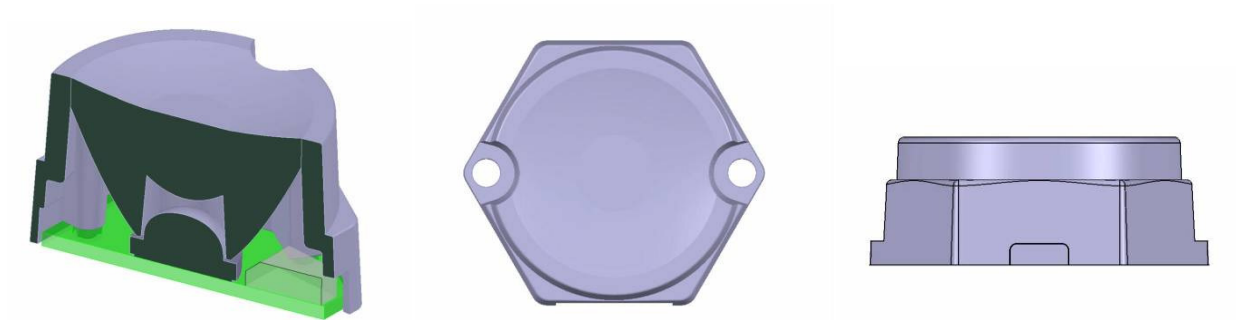

	Felicia ED Dome	Document no: n/a	Revision: 1.1	Page: Page 7 of 15
	Object: Datasheet Felicia EDP7 Dome Warm White	Author: SL	Date: 2010-08-17	

Parameters of the light output

Warm White

Electro-Optical characteristics LED at $I_F=700\text{mA}$, $T_A=25^\circ\text{C}$

Parameter	Symbol	Value			Unit	
		Min	Typ	Max		
Luminous Flux	Y rank ⁽¹⁾	Φ_V	260		340	lm
	Z rank ⁽¹⁾	Φ_V	340		440	lm
Correlated Color Temperature	W* ⁽²⁾	CCT	2900		3000	lm
	V* ⁽²⁾	CCT	3000		3200	lm
CRI	R_a		-	77	-	-
Power	P_o			10	11.2	W
Thermal resistance	$R\theta_{J-B}$		3			$^\circ\text{C}/\text{W}$

(1) See detailed information in chapter "Luminous Flux Bin"

(2) See detailed information in chapter "Binning structure graphical representation"

Colour Spectrum

Warm White

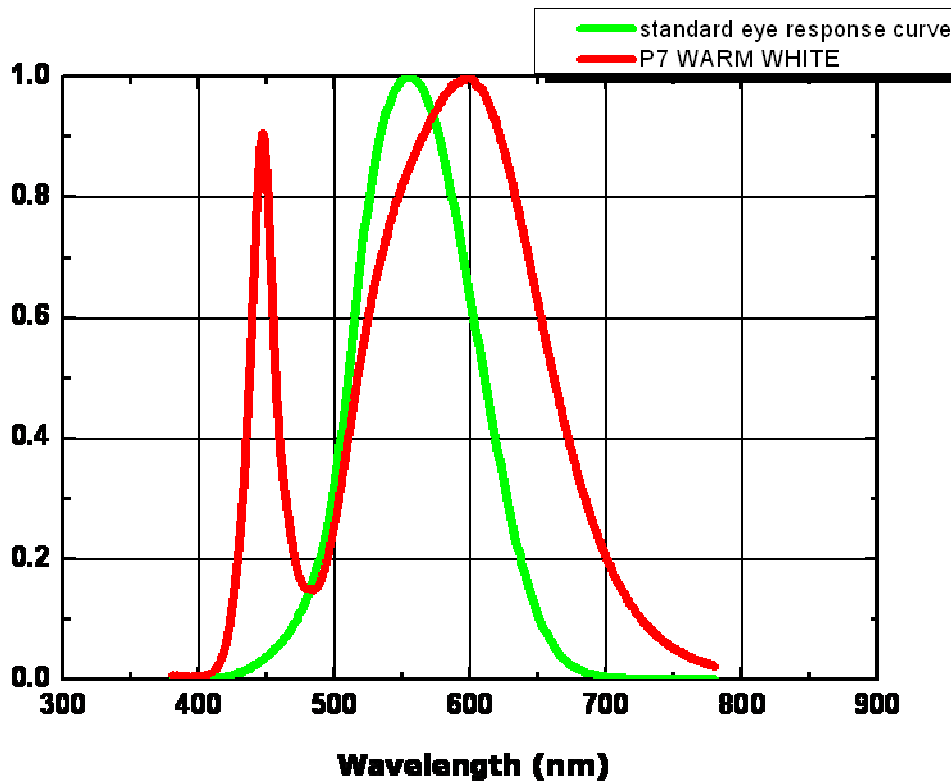

Module Performance Warm White

Voltage vs. Current

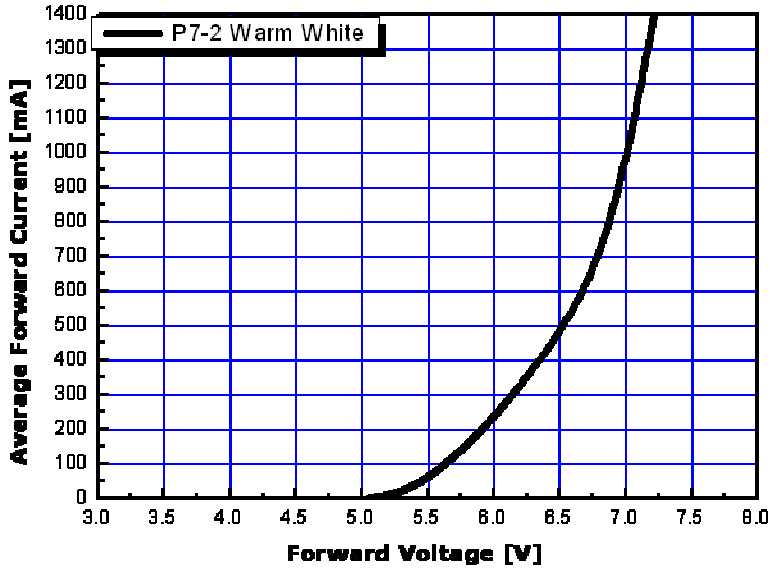

Current vs Flux

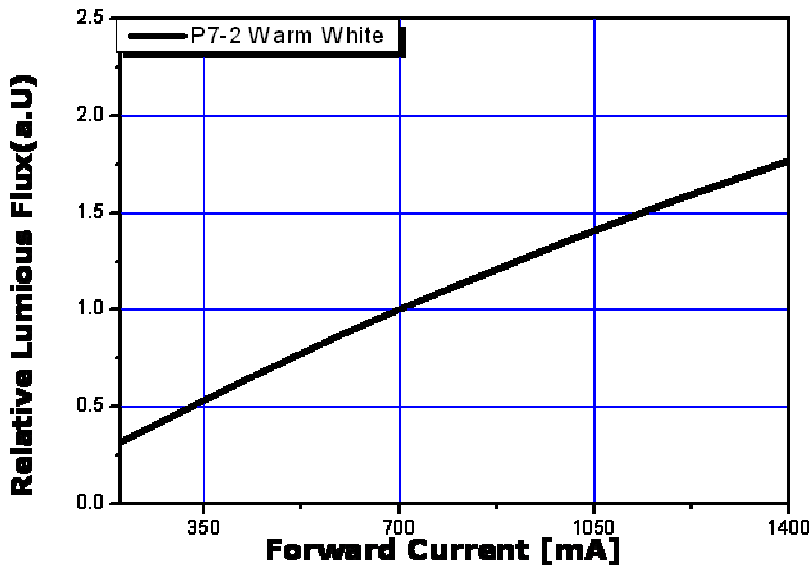

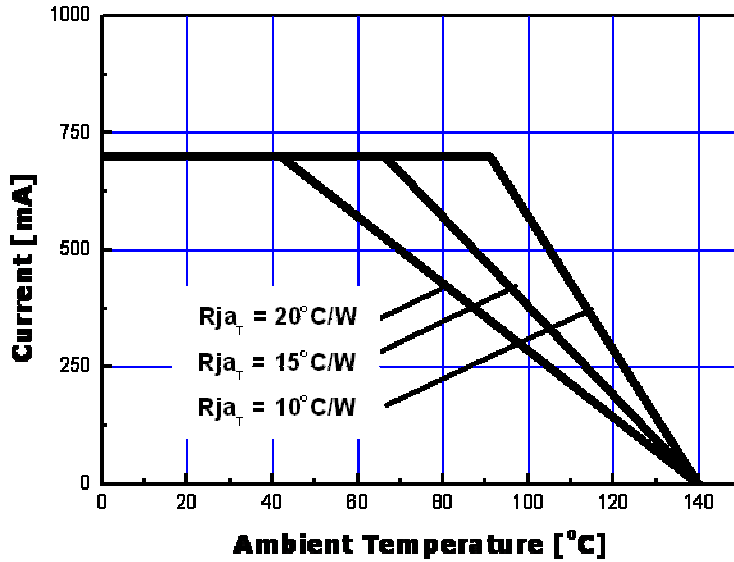

Ambient Temperature vs Allowable Forward Current

Warm White (TJMAX = 140 °C, @700mA)

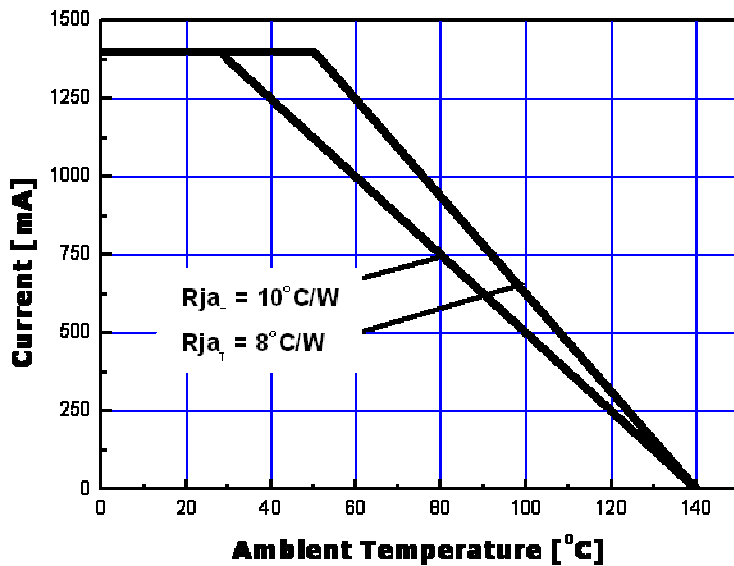

Warm White (TJMAX = 140 °C, @1400mA)



	Felicia ED Dome	Document no: n/a	Revision: 1.1	Page: Page 10 of 15
	Object: Datasheet Felicia EDP7 Dome Warm White	Author: SL	Date: 2010-08-17	

Binning and Labelling

Short form letter for colour

Colour Code	Colour
N	Warm White

Luminous Flux Bins pro LED

Bin Code	Luminous Flux [lm]
Y	260.0 ~ 340.0
Z	340.0 ~ 440.0

Forward Voltage

Vf Rank	Forward Voltage [Vf]
O	6.0~6.5
P	6.5~7.0
Q	7.0~7.5
R	7.5~8.0

Binning structure graphical representation

Warm White Binning (2600 – 3700K)

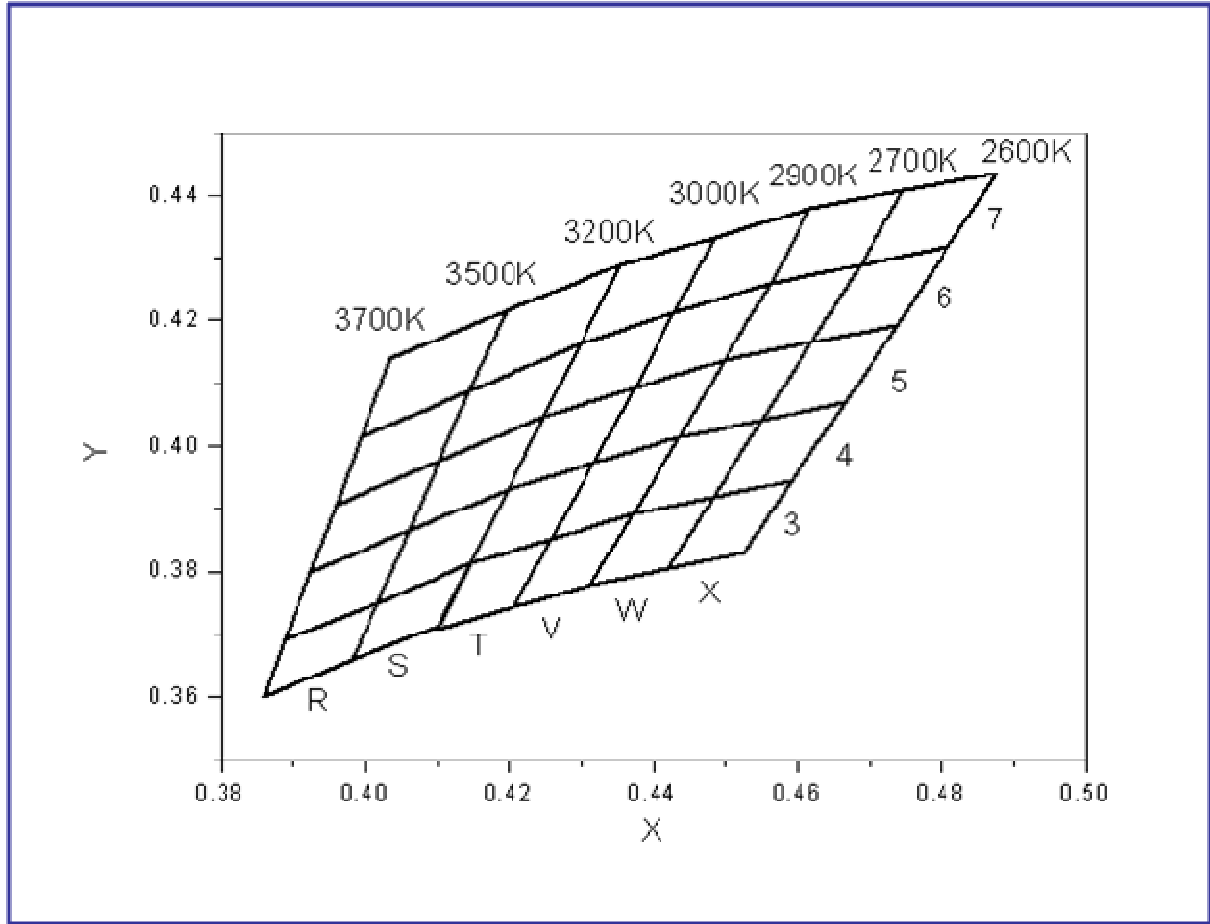

	Felicia ED Dome	Document no: n/a	Revision: 1.1	Page: Page 12 of 15
	Object: Datasheet Felicia EDP7 Dome Warm White	Author: SL	Date: 2010-08-17	

Optics performance

Medium Version

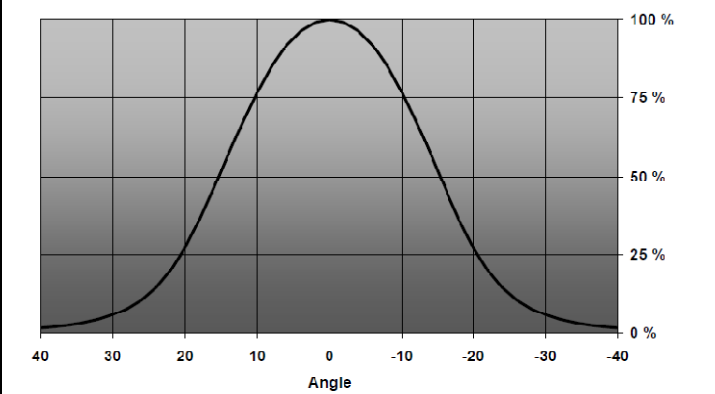
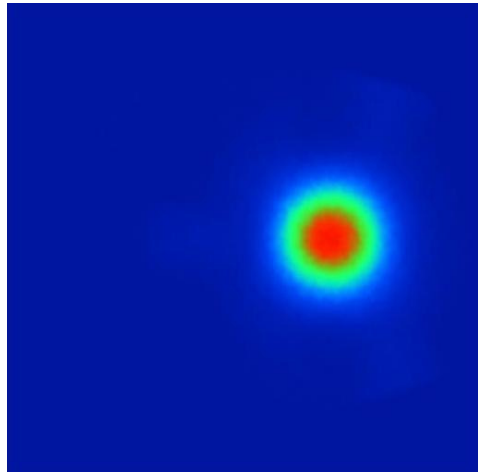

Wide Asymmetric Version of centre 10°

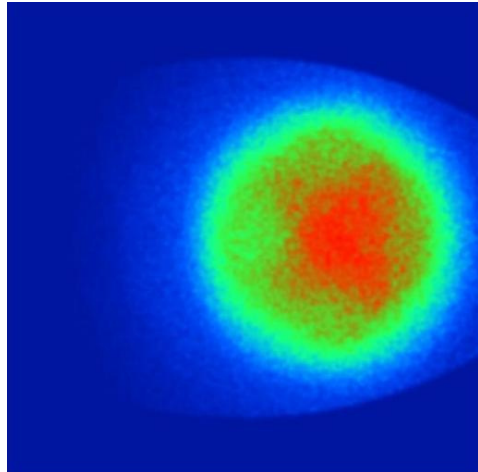

TBD

	Felicia ED Dome	Document no: n/a	Revision: 1.1	Page: Page 13 of 15
	Object: Datasheet Felicia EDP7 Dome Warm White	Author: SL	Date: 2010-08-17	

Measurement Control

The recommended maximum value is 65°C on Tc or measuring point. If this value is exceeded we can't guarantee the function and the life time. The purpose of the measurement is to control the Junction (Tj) temperature of the LED and also control the performance on the whole set up. By the help of the junction temperature (Tj) the average lifetime of the product is known.

The thermal connection is measured in temperature vs. Power.

Measurement points

When the measurement takes place we verify the temperature on different places where the life time expected is depending on maximum temperature.

Measurement points

- TC (- and +)
- LED legs at the soldering point

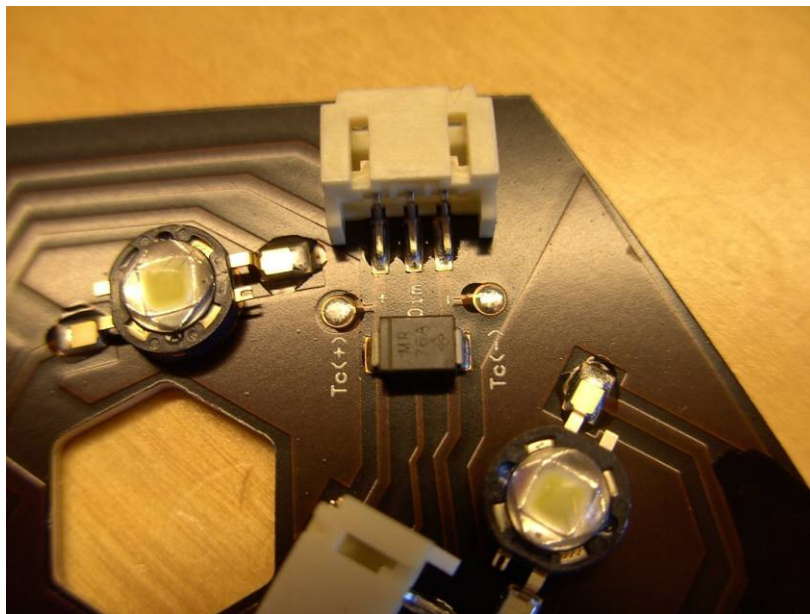

This measurement is to be done when the heat sink is connected properly!

	Felicia ED Dome	Document no: n/a	Revision: 1.1	Page: Page 14 of 15
	Object: Datasheet Felicia EDP7 Dome Warm White	Author: SL	Date: 2010-08-17	

Lifetime

TBD

	Felicia ED Dome	Document no: n/a	Revision: 1.1	Page: Page 15 of 15
	Object: Datasheet Felicia EDP7 Dome Warm White	Author: SL	Date: 2010-08-17	

Precaution for use

- This device should not be used in any type of fluid such as water, oil, organic solvent etc.
- When washing is required, only clean water together with mild soap on the outside of the lens. Washing inside of the LED module is prohibited.
- The appearance and specifications of the product may be modified for improvement without notice.
- Long time exposure of sunlight or occasional UV exposure will cause lens discoloration.
- Opening of the LED module are prohibited due to risk of EMC, dust, grease and other exposures that are out of control.
- The LED Module should always be mounted inside a proper heat sink before it's connected with its proper cores. This due to electrical hazard.
- Please secure proper grounding on the thermal side of the LED module.

ROHS Compliant

All our LED modules are meeting the Restriction of Hazardous Substances (RoHS)!

There has been a growing consensus that Lead Free Systems should increase for the safety of our environment. It is a very serious problem that lead and other harmful materials are being used in commercial and industrial products, causing more and more environmental problems. This has lead to regulations such as RoHS (Restriction of the use of certain Hazardous Substances) from the EU and the Japan Ministry of Trade and Industry (MITI). All LED makers providing products to these countries should comply with these restrictions. In order to meet RoHS regulation, Optoga is strictly implementing a ban on lead and other hazardous materials in its products. This is in compliance with our responsibilities as good corporate citizens.