	Felicia DC Dome ID	Document no: n/a	Revision: 1.7	Page: Page 1 of 18
	Object: Datasheet Felicia DC Dome 12-36VDC	Author: SL	Date: 2009-09-17	

Felicia LED Module Solution



This LED module is designed with internal driver and are therefore very easy to connect in applications for 12-36VDC or with external wall outlet transformer. The efficiency are the highest available on the market for such applications. Lenses are available when needed from 10 – 60° in viewing angle.

Description

Optodrive Felicia series is designed for high current operation and high flux output applications. Optodrive LED's thermal management performance exceeds other power LED solutions. It incorporates state of the art SMD design and Thermal emission material as well as the most efficient switch technology. The white color Optodrive LED solution is the first built in driver package designed, using high performance power chips and rendering a perfect white light.

Light Performance

The standard light temperature is 2950, 4000 and 5350 Kelvin with Colour Rendering Index with a type value of 93 from 2650 up to 4500K. The light temperatures 5350 K and above have a CRI of 70.

	Felicia DC Dome ID	Document no: n/a	Revision: 1.7	Page: Page 2 of 18
	Object: Datasheet Felicia DC Dome 12-36VDC	Author: SL	Date: 2009-09-17	

Pages for reference:

Short form Characteristics.....	3
Parameters of the Lens system	4
Article number structure.....	4
Accessories.....	5
Wiring diagram	5
Dimensions LED Module:.....	6
Parameters of the light output.....	7
White LED	7
Normal White LED	8
Warm White	9
Electro Optical data.....	10
<i>Forward Current vs. Luminous Flux</i>	10
<i>Junction Temperature Characteristics</i>	10
Short form letter for binning and labeling.....	11
<i>Colour</i>	11
<i>Luminous Flux Bins</i>	11
Binning structure graphical representation.....	12
<i>Pure White Binning (4500 – 10000K)</i>	12
<i>Normal White Binning (3500 – 4500K)</i>	12
<i>Warm White Binning (2650 – 3500K)</i>	13
<i>Colour shift vs. Power (Neutral White 3730K)</i>	13
<i>Optics</i>	14
Measurement Control	16
Lifetime (Calculated)	16
Test and Performance.....	17
<i>EMC (Emission and Immunity)</i>	17
<i>Safety of Laser products</i>	17
Precaution for use.....	18
ROHS Compliant	18

	Felicia DC Dome ID	Document no: n/a	Revision: 1.7	Page: Page 3 of 18
	Object: Datasheet Felicia DC Dome 12-36VDC	Author: SL	Date: 2009-09-17	

Short form Characteristics

Mechanical:

Board dimensions:	34.56 mm diameter
Assembly holes:	2 x 3.2 mm
Connector:	PHR-3 or similar
Height:	16.6 mm

Electrical:

Number of LED's:	1
Power supply:	12 - 36VDC
LED current:	350 mA +/-10% (<i>1W version</i>) 700 mA +/-10% (<i>3W version</i>)

Dimming Signal:

PWM high level:	4 – 7V
PWM low level:	0 – 0,5V
PWM frequency ¹ :	100 – 20kHz

Efficiency: >80

Reversed polarity protection:	Yes
Transient protection:	Yes
Overvoltage protection:	
Dimming-signal:	Yes

Environmental operating conditions:

Temperature range:	-40°C to 65°C (Absolute maximum temp Tc 65°C)
Relative Humidity:	10-75%
Ambient air pressure:	500-1060 HPa

Notes:

1. Frequencies below 20 kHz will create audible sound in inductor. Dimming at high frequencies above 10 kHz is very non-linear and smooth dimming can only be reached with processor controlled software.

	Felicia DC Dome ID	Document no: n/a	Revision: 1.7	Page: Page 4 of 18
	Object: Datasheet Felicia DC Dome 12-36VDC	Author: SL	Date: 2009-09-17	

Parameters of the Lens system

The lens system is mounted and fixated on to the PCB with double sided adhesive tape. The light parameters are according to the following:

<i>Version</i>	<i>Viewing Angle</i>	<i>FWHM Angle</i>
Felicia Real Spot	10°	±5°
Felicia Smooth Spot	11°	±5.5°
Felicia Medium	26°	±13°
Felicia Rectangular	36° x 24°	±18° x 12°

Lens material is an optical grade PMMA with high UV and temperature resistance material and the lens holder material is PC

- Allows use of high current and temperature conditions
- Best available optical efficiency, up to 90%
- Very even color distribution over the whole beam angle
- Integrated holder. Fastening to heat sink with two screws

Article number structure

*Article number: Felicia ID010121xWS**zz*

Felicia: Module name
 ID: Built-In Driver
 01: Power (1W or 3W)
 012: Voltage (12-36VDC)
 1: Amount of LED
 x: Color
 W: Luminous Flux Bin
 S**: Binning Color and standard versions (CCT)
 zz: Viewing angle

	Felicia DC Dome ID	Document no: n/a	Revision: 1.7	Page: Page 5 of 18
	Object: Datasheet Felicia DC Dome 12-36VDC	Author: SL	Date: 2009-09-17	

Accessories

Dimmers:

- 1 channel with external dimmer switch
- 6 channel with external dimmer switch

The dimmers are for digital dimming and can be set up in a network. The dimmers work for all types of Optodrive modules with built-in driver.

Wires:

- From 60 mm up to 2000 mm

Wiring diagram

See separate wiring diagram documentation.

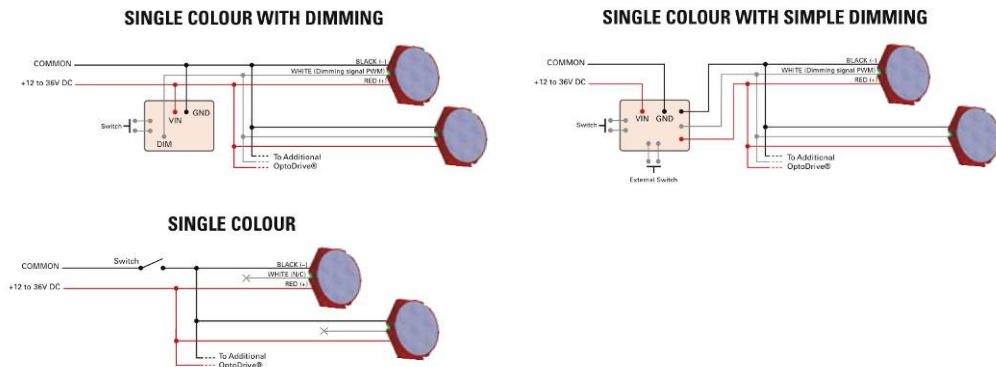

	Felicia DC Dome ID	Document no: n/a	Revision: 1.7	Page: Page 6 of 18
	Object: Datasheet Felicia DC Dome 12-36VDC	Author: SL	Date: 2009-09-17	

Dimensions LED Module:

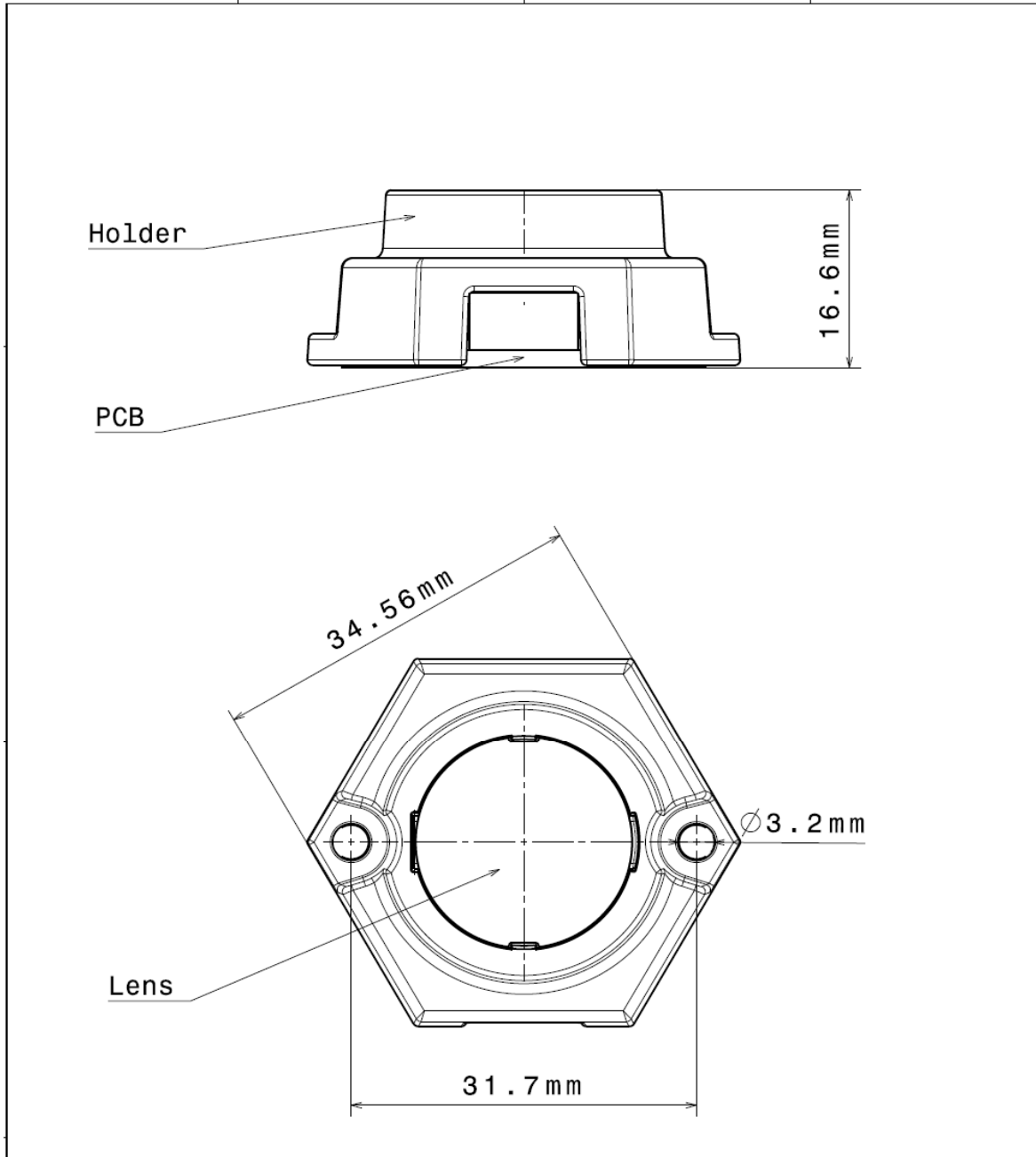

This drawing is our property. It can't be reproduced or communicated without our written agreement.					
DRAWN BY RM		DATE 03.12.2007		DRAWING TITLE Felicia-holder-lens assembly	
CHECKED BY HH		DATE 03.12.2007		SIZE A4	
DESIGNED BY HH		DATE 03.12.2007		DRAWING NUMBER 	
		SCALE 2:1		REV 0.1	
		WEIGHT (g)		SHEET 1/1	

	Felicia DC Dome ID	Document no: n/a	Revision: 1.7	Page: Page 7 of 18
	Object: Datasheet Felicia DC Dome 12-36VDC	Author: SL	Date: 2009-09-17	

Parameters of the light output

White LED

Electro-Optical characteristics LED at $I_F=350\text{mA}$, $T_A=25^\circ\text{C}$ (1W version)

Parameter	Rank / Binning	Symbol	Value			Unit
			Min	Typ	Max	
Luminous Flux	T rank ⁽¹⁾	Φ_V	70	80	91	lm
	U1 rank ⁽¹⁾	Φ_V	91		100	lm
	U2 rank ⁽¹⁾		100		118.5	
Correlated Color Temperature	SV* rank ⁽²⁾	CCT	5000	5350	5700	K
CRI		R_a	-	70	-	-
Power		P_o	1.2	1.35	1.5	W
Thermal resistance		$R\theta_{J-B}$	8.5			$^\circ\text{C}/\text{W}$

(1) See detailed information in chapter "Luminous Flux Bin"

(2) See detailed information in chapter "Binning structure graphical representation"

Electro-Optical characteristics LED at $I_F=700\text{mA}$, $T_A=25^\circ\text{C}$ (3W version)

Parameter	Symbol	Value			Unit	
		Min	Typ	Max		
Luminous Flux	T rank	Φ_V	126	144	164	lm
	U1 rank	Φ_V	164		180	lm
	U2 rank	Φ_V	180		213	
Correlated Color Temperature	SV rank	CCT	5000	5350	5700	K
CRI		R_a	-	70	-	-
Power		P_o	2.4	2.7	3	W
Thermal resistance		$R\theta_{J-B}$	8.5			$^\circ\text{C}/\text{W}$

Colour Spectrum

White

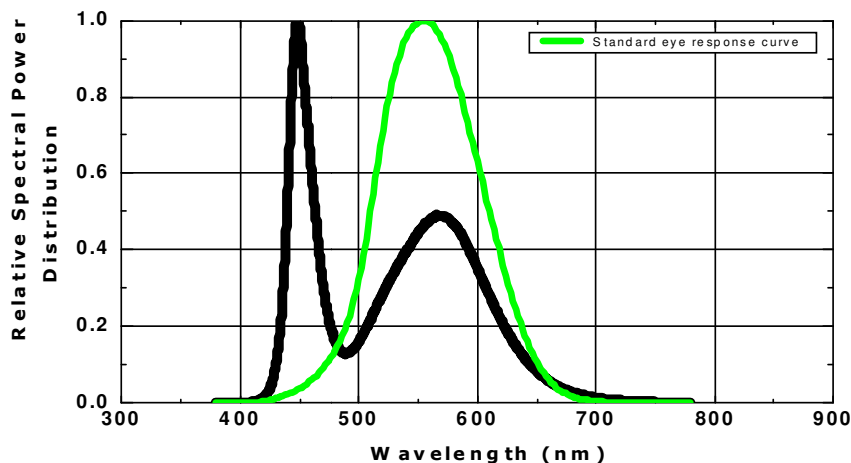

	Felicia DC Dome ID	Document no: n/a	Revision: 1.7	Page: Page 8 of 18
	Object: Datasheet Felicia DC Dome 12-36VDC	Author: SL	Date: 2009-09-17	

Normal White LED

Electro-Optical characteristics LED at $I_F=350\text{mA}$, $T_A=25^\circ\text{C}$ (1W version)

Parameter		Symbol	Value			Unit
			Min	Typ	Max	
Luminous Flux	S1 rank ⁽¹⁾	Φ_V	54	58	60	lm
	S2 rank ⁽¹⁾	Φ_V	60	65	70	lm
Correlated Color Temperature	SR* ⁽²⁾	CCT	3500	3660	3820	lm
	ST* ⁽²⁾	CCT	4150	4325	4500	lm
CRI		R_a	-	93	-	-
Power		P_O	1.2	1.35	1.5	W
Thermal resistance		$R\theta_{J-B}$	8.5			$^\circ\text{C}/\text{W}$

(1) See detailed information in chapter "Luminous Flux Bin"

(2) See detailed information in chapter "Binning structure graphical representation"

Electro-Optical characteristics LED at $I_F=700\text{mA}$, $T_A=25^\circ\text{C}$ (3W version)

Parameter		Symbol	Value			Unit
			Min	Typ	Max	
Luminous Flux	S1 rank	Φ_V	97	104	108	lm
	S2 rank	Φ_V	108	117	126	lm
Correlated Color Temperature	SR	CCT	3500	3660	3820	lm
	ST	CCT	4150	4325	4500	lm
CRI		R_a	-	93	-	-
Power		P_O	2.4	2.7	3	W
Thermal resistance		$R\theta_{J-B}$	8.5			$^\circ\text{C}/\text{W}$

Colour Spectrum

Neutral White

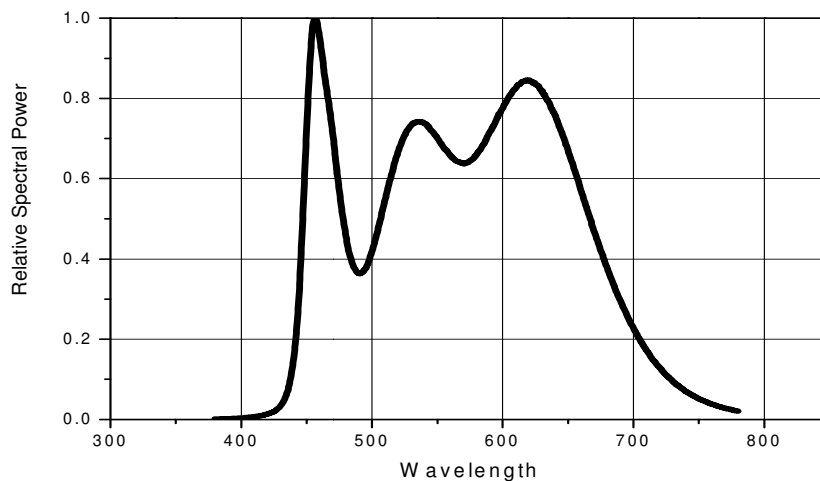

	Felicia DC Dome ID	Document no: n/a	Revision: 1.7	Page: Page 9 of 18
	Object: Datasheet Felicia DC Dome 12-36VDC	Author: SL	Date: 2009-09-17	

Warm White

Electro-Optical characteristics LED at $I_F=350\text{mA}$, $T_A=25^\circ\text{C}$ (1W version)

Parameter		Symbol	Value			Unit
			Min	Typ	Max	
Luminous Flux	S1 rank ⁽¹⁾	Φ_V	54	58	60	lm
	S2 rank ⁽¹⁾	Φ_V	60	65	70	lm
Correlated Color Temperature	SJ* ⁽²⁾	CCT	2850	2950	3050	lm
	SK* ⁽²⁾	CCT	3050	3150	3250	lm
CRI		R_a	-	93	-	-
Power		P_o	1.2	1.35	1.5	W
Thermal resistance		$R\theta_{J-B}$	8.5			$^\circ\text{C}/\text{W}$

(1) See detailed information in chapter "Luminous Flux Bin"

(2) See detailed information in chapter "Binning structure graphical representation"

Electro-Optical characteristics LED at $I_F=700\text{mA}$, $T_A=25^\circ\text{C}$ (3W version)

Parameter		Symbol	Value			Unit
			Min	Typ	Max	
Luminous Flux	S1 rank	Φ_V	97	104	108	lm
	S2 rank	Φ_V	108	117	126	lm
Correlated Color Temperature	SJ	CCT	2850	2950	3050	lm
	SK	CCT	3050	3150	3250	lm
CRI		R_a	-	93	-	-
Power		P_o	2.4	2.7	3	W
Thermal resistance		$R\theta_{J-B}$	8.5			$^\circ\text{C}/\text{W}$

Colour Spectrum

Warm White

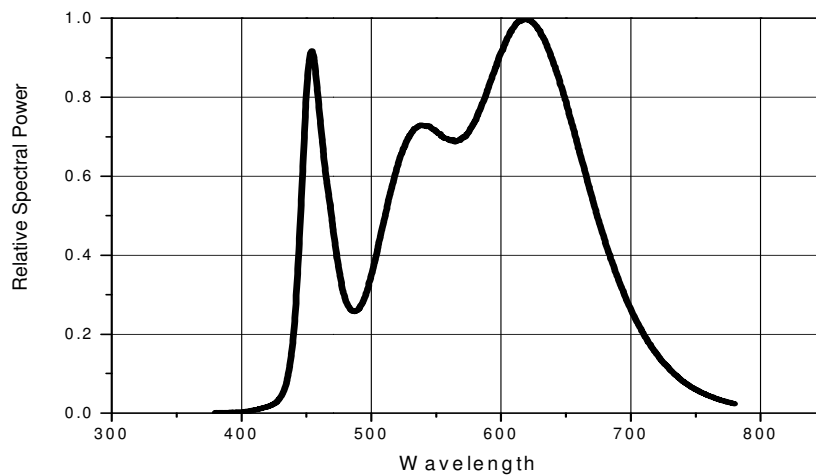

	Felicia DC Dome ID	Document no: n/a	Revision: 1.7	Page: Page 10 of 18
	Object: Datasheet Felicia DC Dome 12-36VDC	Author: SL	Date: 2009-09-17	

Electro Optical data

Forward Current vs. Luminous Flux

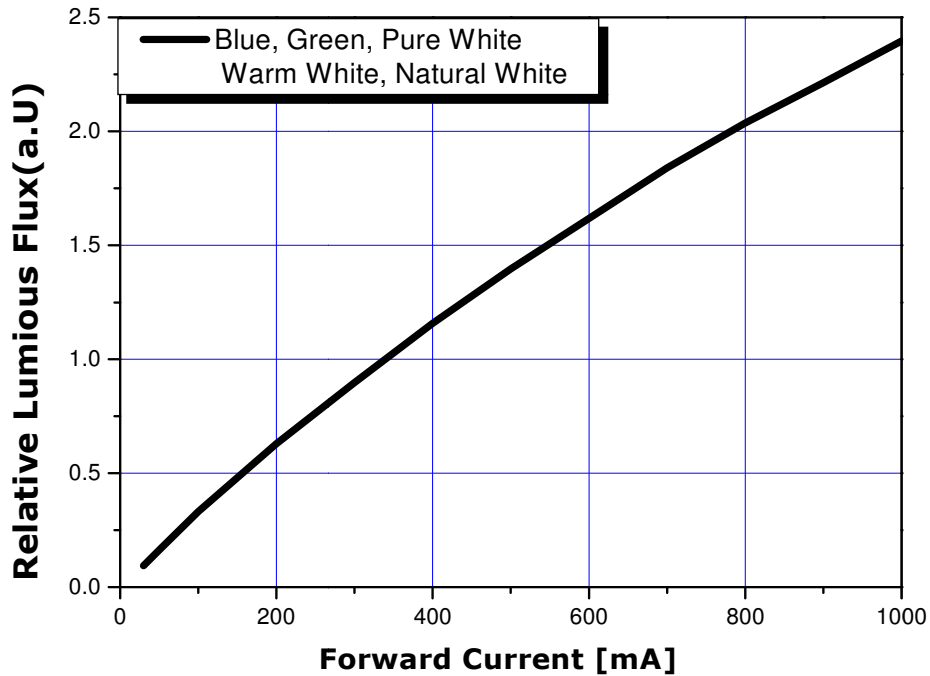

Junction Temperature Characteristics

Forward Voltage Shift vs. Junction Temperature at $I_F=350\text{mA}$

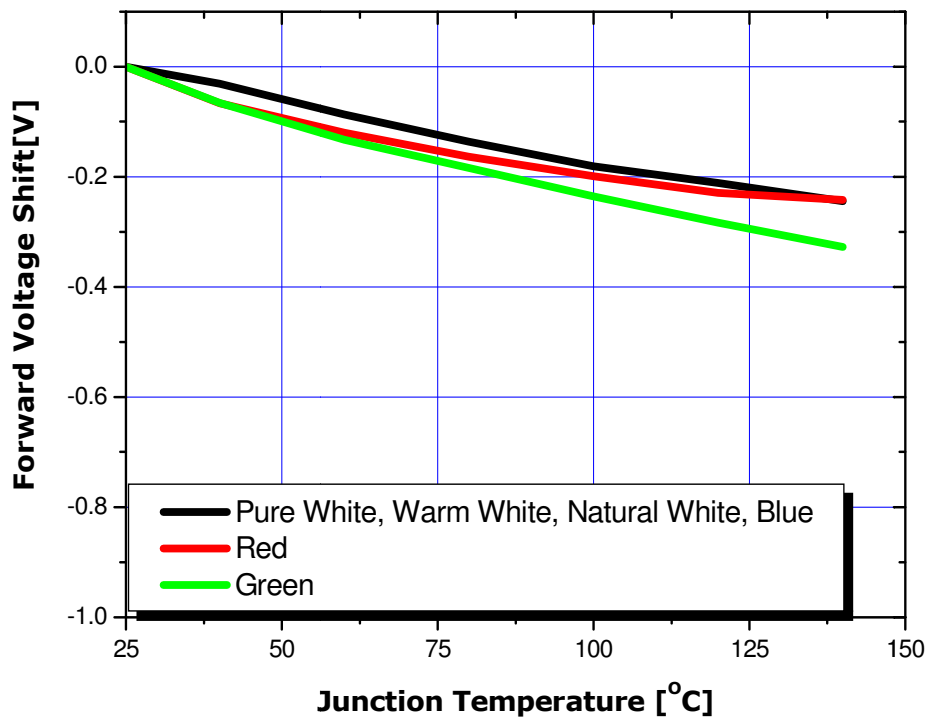

	Felicia DC Dome ID	Document no: n/a	Revision: 1.7	Page: Page 11 of 18
	Object: Datasheet Felicia DC Dome 12-36VDC	Author: SL	Date: 2009-09-17	

Short form letter for binning and labeling

Colour

Colour Code	Colour
W	White
S	Neutral White
N	Warm White
B	Blue
G	Green
R	Red
A	Amber

Luminous Flux Bins

Bin Code	Luminous Flux [lm]	
J	6 ~ 8.5	
K	8.5 ~ 11.0	
L	11.0 ~ 14.5	
M	14.5 ~ 19.0	
O	19.0 ~ 24.5	
P	24.5 ~ 32.0	
Q	32.0 ~ 41.5	
R	41.5 ~ 54.0	
S	S1	54.0 ~ 60.0
	S2	60.0 ~ 70.0
T	T1	70.0 ~ 80.0
	T2	80.0 ~ 91.0
U	U1	91.0 ~ 100.0
	U2	100.0 ~ 118.5
V	V1	118.5 ~ 136.0
	V2	136.0 ~ 118.5
W	W1	91.0 ~ 154.0
	W2	154.0 ~ 177.0
X	X1	177.0 ~ 200.0
	X2	200.0 ~ 230.0
Y	260.0 ~ 340.0	

Binning structure graphical representation

Pure White Binning (4500 – 10000K)

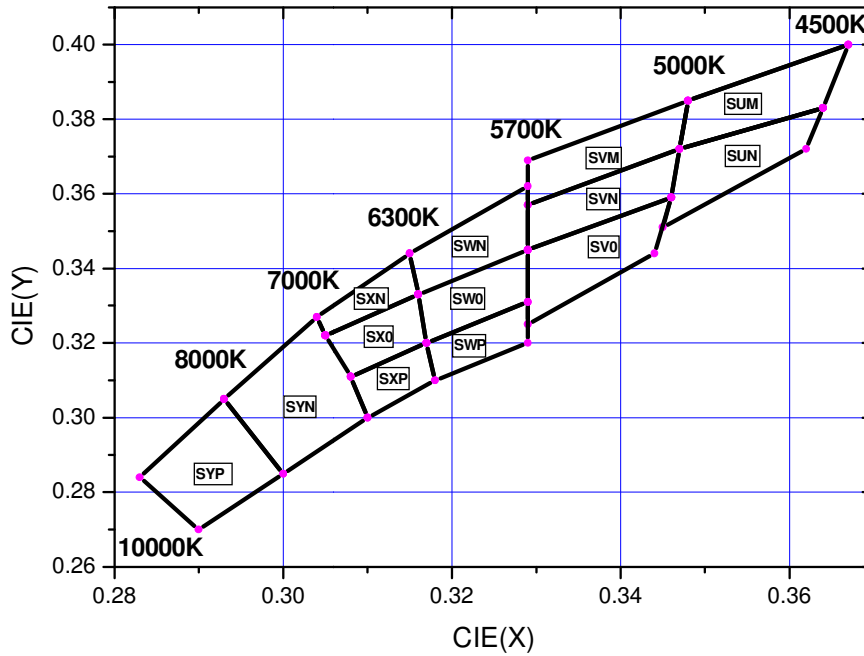

Normal White Binning (3500 – 4500K)

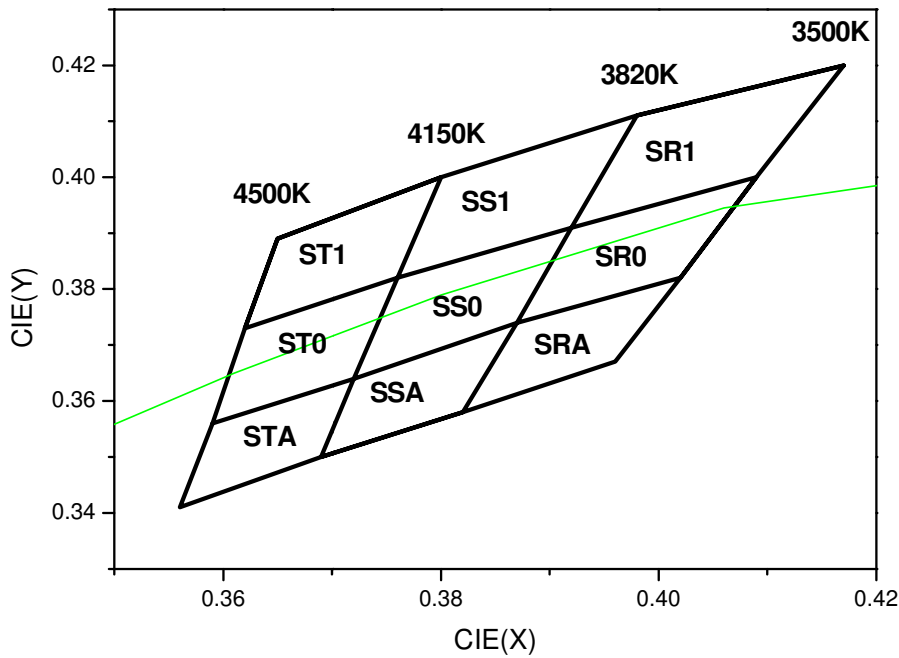

	Felicia DC Dome ID	Document no: n/a	Revision: 1.7	Page: Page 13 of 18
	Object: Datasheet Felicia DC Dome 12-36VDC	Author: SL	Date: 2009-09-17	

Warm White Binning (2650 – 3500K)

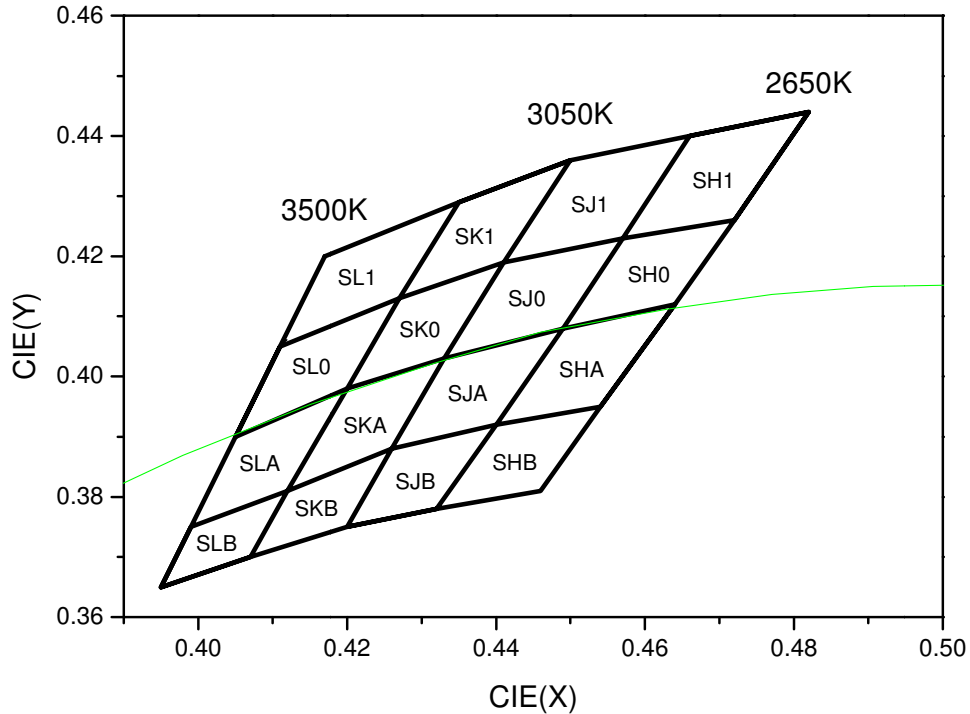

Colour shift vs. Power (Neutral White 3730K)

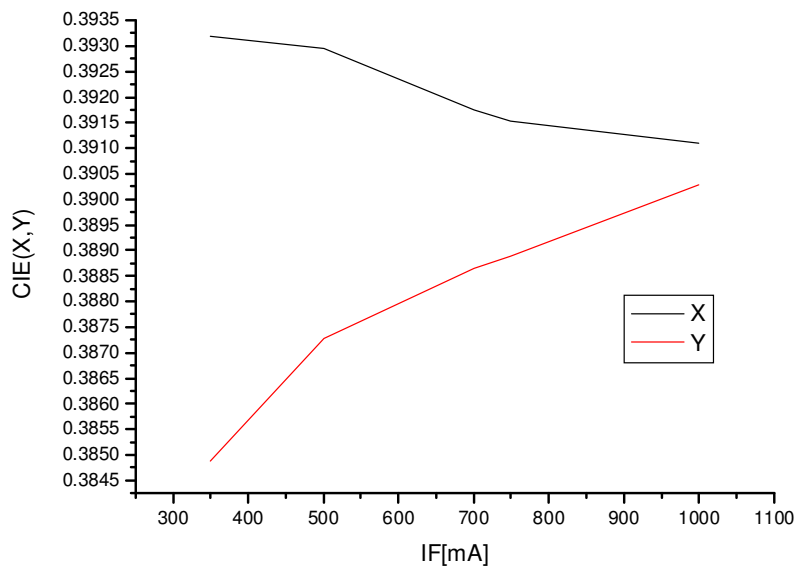

The colour shift looks very drastic in the diagram but there are very narrow lines and in real life the colour shift is not detectable

Optics

Real Spot Version

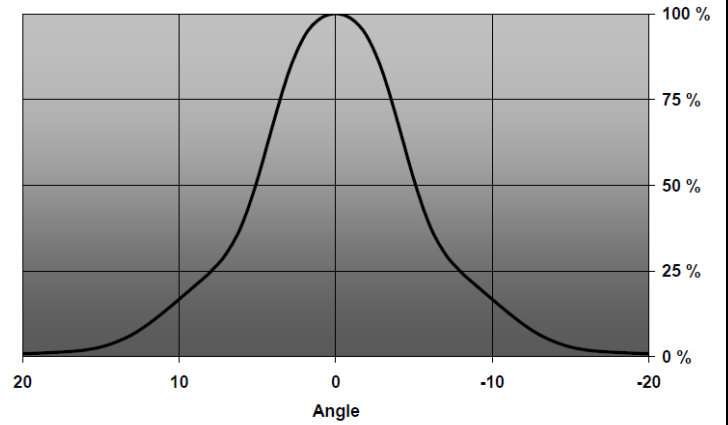

Smooth Spot Version

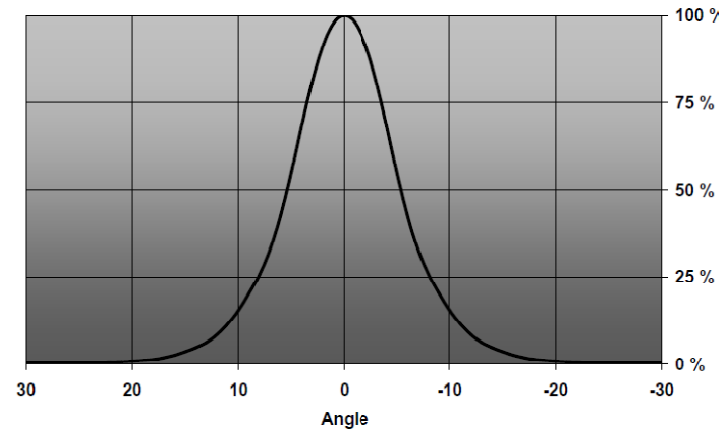

Medium Version

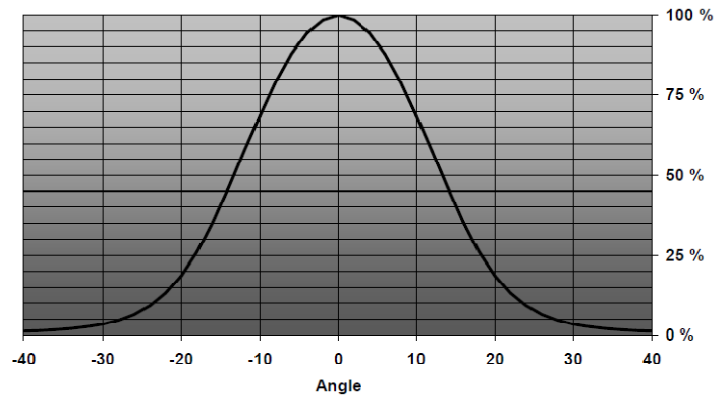



Felicia DC Dome ID

Document no:
n/a

Revision:
1.7

Page:
Page 15 of 18

Object:
Datasheet Felicia DC Dome 12-36VDC

Author:
SL

Date:
2009-09-17

Rectangular Version

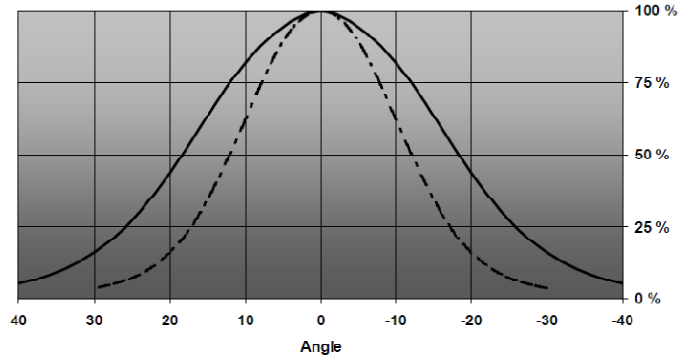

	Felicia DC Dome ID	Document no: n/a	Revision: 1.7	Page: Page 16 of 18
	Object: Datasheet Felicia DC Dome 12-36VDC	Author: SL	Date: 2009-09-17	

Measurement Control

The recommended maximum value is 65°C on Tc or measuring point. If this value is exceeded we can't guarantee the function and the life time. The purpose of the measurement is to control the Junction (Tj) temperature of the LED and also control the performance on the whole set up. By the help of the junction temperature (Tj) the average lifetime of the product is known.

The thermal connection is measured in temperature vs. Power.

Measurement points

When the measurement takes place we verify the temperature on different places where the life time expected is depending on maximum temperature.

Measurement points

- TC (- and +)
- LED legs at the soldering point

This measurement is to be done when the heat sink is connected properly!

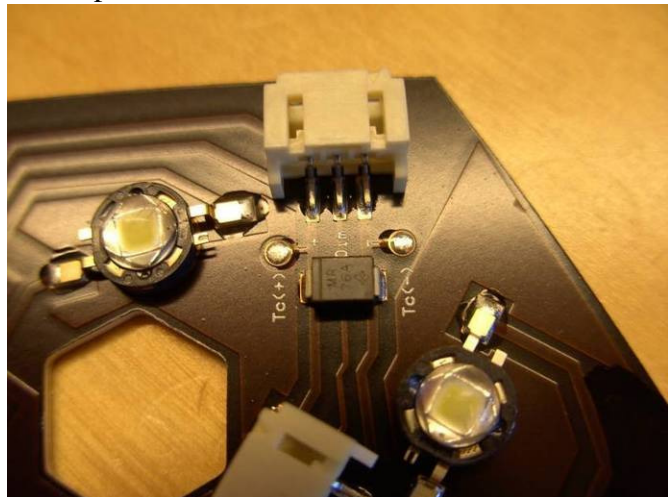

Lifetime (Calculated)

The lifetime is calculated at the maximum temperature recommended at the Tc (measuring point). It is important not to exceed this recommendation; you find more information under the chapter "measurement control".

Unit	Tc Maximum	50 % degradation	30 % degradation
Felicia 1.3W (350mA)	65° C	>100 000 hours	67 500 Hours
Felicia 3 W (700 mA)	65° C	70 000 hours	37 500 hours

	Felicia DC Dome ID	Document no: n/a	Revision: 1.7	Page: Page 17 of 18
	Object: Datasheet Felicia DC Dome 12-36VDC	Author: SL	Date: 2009-09-17	

Test and Performance

EMC (Emission and Immunity)

The product has been tested and is meeting the demand perfect according to the following standards:

Emission: SS-EN55015:2007

Immunity: SS-EN 61547:1996 + A1:2001, EN61000-4-2, -4, -6

<i>Test Performed</i>	<i>Environmental</i>	<i>Standard</i>
Emission	Conducted disturbance	SS-EN 55015:2007
Emission	Radiated disturbance	SS-EN 55015:2007
Immunity SS-EN61547, A1:2001	Electrostatic discharge ESD	EN 61000-4-2:1995
Immunity SS-EN61547, A1:2001	Fast Transients	EN 61000-4-4:1995
Immunity SS-EN61547, A1:2001	Induced radio frequency field	EN 61000-4-6:1995

Any questions please take contact for more detailed information.

Safety of Laser products

The package is meeting the demands of safety According to IEC 60825-1. Safety of Laser products and are identified as a Laser Product Class 1.

<i>Test Performed</i>	<i>Environmental</i>	<i>Standard</i>
IEC 60825-1	Safety of laser products	IEC 60825-1:1993 + A1:1997 + A2:2001

Any questions please take contact for more detailed information.

	Felicia DC Dome ID	Document no: n/a	Revision: 1.7	Page: Page 18 of 18
	Object: Datasheet Felicia DC Dome 12-36VDC	Author: SL	Date: 2009-09-17	

Precaution for use

- This device should not be used in any type of fluid such as water, oil, organic solvent etc.
- When washing is required, water and mild soap only on the outside should be used.
- When the LEDs are illuminating, operating current should be decided after considering the package maximum temperature.
- The appearance and specifications of the product may be modified for improvement without notice.
- Long time exposure of sunlight or occasional UV exposure will cause lens discoloration.

ROHS Compliant

All our LED modules are meeting the Restriction of Hazardous Substances (RoHS)!

There has been a growing consensus that Lead Free Systems should increase for the safety of our environment. It is a very serious problem that lead and other harmful materials are being used in commercial and industrial products, causing more and more environmental problems. This has led to regulations such as RoHS (Restriction of the use of certain Hazardous Substances) from the EU and the Japan Ministry of Trade and Industry (MITI). All LED makers providing products to these countries should comply with these restrictions. In order to meet RoHS regulation, Optoga is strictly implementing a ban on lead and other hazardous materials in its products. This is in compliance with our responsibilities as good corporate citizens.